



1x1 Seat arrangement



2x2 Seat arrangement

INTERIOR

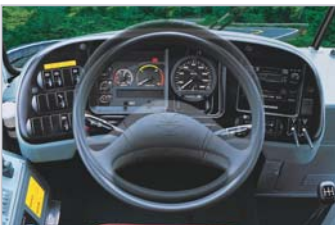

Tilt & Telescopic steering wheel



Driver console box



Acryl type sunvisor



Driver solar screen



Hot & cold cabinet (option)



Air parking brake



Emergency door (option)



Air pressure switch

POWER

DE12, DIESEL

Displacement : 11,051cc
 Max horse power : 225ps/2,200rpm
 Max torque : 81.5kg.m/1,400rpm



Engine

DL 08, DIESEL(EURO III)

Displacement : 7,640cc
 Max horse power : 300ps/2,200rpm
 Max torque : 115kg.m/1,200rpm

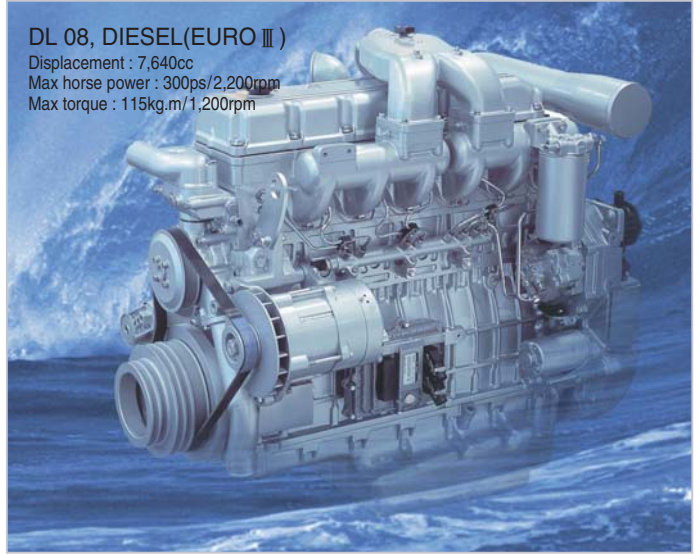

Engine (option)

POWER

GE12TI, CNG

Displacement : 11,051cc
 Max horse power : 290ps/2,200rpm
 Max torque : 115kg.m/1,320rpm



Engine (option)

SUSPENSION

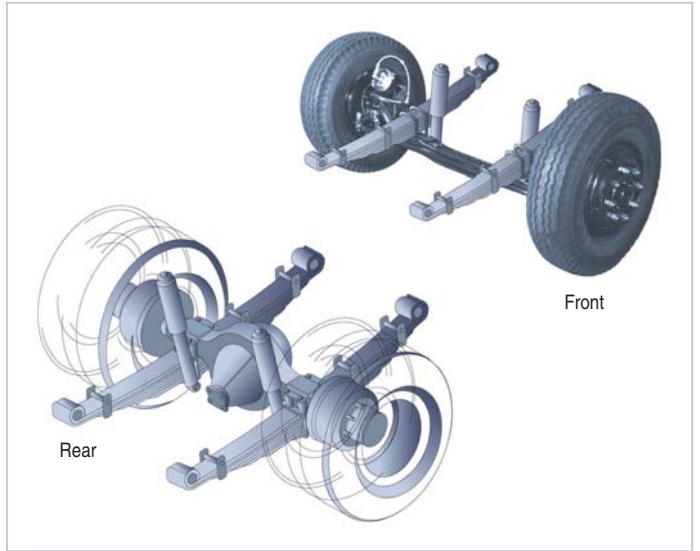

Leaf suspension

EXTERIOR



Rear folding door (option)



RHD (option)



Middle folding door (option)



CNG Tank (option)



Engine room

BS106 STANDARD SPECIFICATION

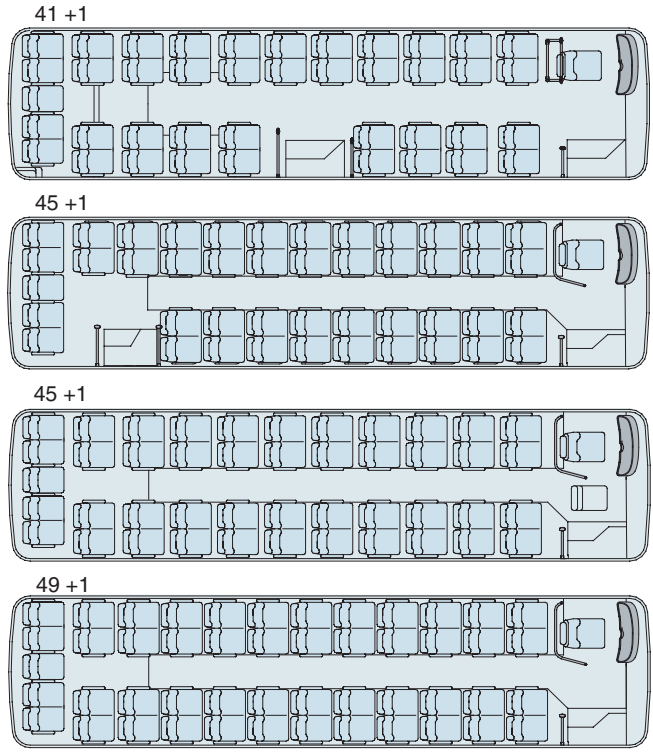
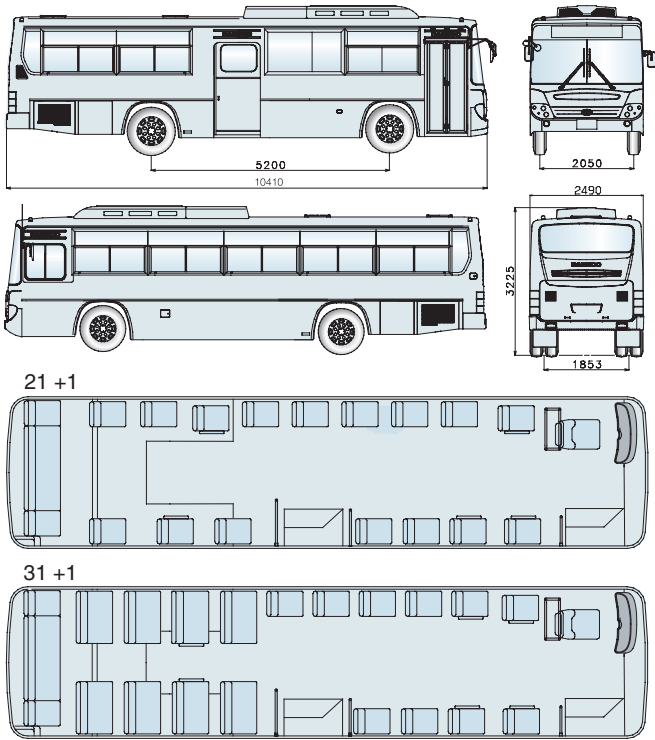

Major Specifications

BODY STRUCTURE	RIVETLESS SKELETON, STEEL BODY
STEERING POSITION	LEFT HAND DRIVE
ENGINE MOUNTING	REAR
PASSENGER CAPACITY	NON-CITY : 45+1 PERSONS CITY : 21+(82)+1 PERSONS

External Dimensions (mm)

OVERALL LENGTH	10,410
OVERALL WIDTH	2,490
OVERALL HEIGHT	3,225
WHEEL BASE	5,200
BODY OVERHANG (FRONT)	2,100
BODY OVERHANG (REAR)	3,110
TREAD (FRONT)	2,050
TREAD (REAR)	1,853

Internal Dimensions (mm)

INSIDE LENGTH	9,908	PERMISSIBLE G.V.W	16,500
INSIDE WIDTH	2,380	CURB WEIGHT	9,015
INSIDE HEIGHT	1,970	G.V.W	INTER-CITY : 12,005 CITY : 15,775

Weight (kg)

Performance

MAX SPEED	NON-CITY : 102km/h CITY : 86km/h
MIN TURNING RADIUS	9.9m
GRADEABILITY(TAN θ)	NON-CITY : 0.37 CITY : 0.29

Frame

SEMI MONOCOQUE TYPE

Engine

MODEL	DE12, DIESEL
TYPE	4 CYCLE, WATER COOLED
NO. OF CYLINDER	6, IN-LINE
BORE & STROKE	123 X 155mm
DISPLACEMENT	11,051cc
MAX HORSE POWER	225ps/2,200rpm
MAX TORQUE	81.5kg.m/1,400rpm
COMPRESSION RATIO	17.1:1
AIR CLEANER	DRY SINGLE PAPER ELEMENT

Transmission

GEAR BOX	5 FORWARD & 1 REVERSE					
	1st	2nd	3rd	4th	5th	REV.
NON-CITY	5.405	3.447	1.739	1.000	0.738	5.650
CITY	6.571	3.807	2.201	1.463	1.000	6.240

Suspension

SEMI-ELLIPTICAL ALLOY STEEL HEAVY DUTY LEAF SPRING
WITH HYDRAULIC DOUBLE ACTING TELESCOPIC
SHOCK ABSORBER

Wheel & Tire

TIRE	10.00-20-16PR TUBE TYPE
WHEEL	7.00T-20 WHEEL

Steering

OPERATION	RECIRCULATED BALL WITH INTEGRAL POWER ASSISTED BY OIL
GEAR RATIO	22.4 : 1
STEERING COLUMN	TILT & TELESCOPIC
STEERING WHEEL	2 SPOKE WHEEL WITH HORN BUTTON

Air Service

AIR PRESSURE	9.0kg/cm ²
AIR TANK CAPACITY	MAIN 50L, BRAKE 25L+35L
AIR TAP FOR TIRE INFLATION	
AIR DRYER	

Brake

SERVICE BRAKE	FULL AIR DUAL CIRCUIT BRAKE SYSTEM
DRUM SIZE	FRONT 410mm, REAR 410mm
LINING (w/t)	FRONT 155/19mm, REAR 220/19mm
LINING MATERIAL	NON-ASBESTOS
PARKING BRAKE	SPRING ACTUATOR AT REAR WHEEL SPRING CHAMBER TYPE
AUXILIARY BRAKE	EXHAUST BRAKE-AIR OPERATED

Clutch

TYPE	DRY SINGLE PLATE WITH COIL SPRING DAMPER
FACING DIMENSION	OUTSIDE DIAMETER 430mm, THICKNESS 5mm
MATERIAL	NON-ASBESTOS

BS106 STANDARD SPECIFICATION

Axle		Door	
FRONT AXLE		ENTRANCE DOOR	FRONT
TYPE	REVERSE ELLIOT 'I' BEAM	TYPE	2 SECTION INWARD FOLDING DOOR
CAPACITY	6,000kg	OPERATING	ELECTRICALLY CONTROLLED WITH AIR ASSIST
REAR AXLE		EXIT DOOR	CITY : MIDDLE
TYPE	BANJO FULL FLOATING	TYPE	1 SECTION SLIDING DOOR
CAPACITY	10,500kg	OPERATING	ELECTRICALLY CONTROLLED WITH AIR ASSIST
FINAL GEAR RATIO	NON-CITY : 39/7(5.571) HYPOID	SAFETY DEVICE	AIR PRESSURE SWITCH
	CITY : 39/8(4.875) HYPOID		
Fuel Tank		Entrance Step	
NON-CITY : 210L	CITY : 200L	NUMBER OF STEP	2 STEP
		MATERIAL	NON-CITY : PLAIN STEEL+MAT, WALL-PLAIN STEEL
			CITY : FLOOR-CHECKED STEEL, WALL-PLAIN STEEL
Horn		STEP MOULDING	ALUMINUM
ELECTRIC TYPE		Floor	
Wiper Arm & Motor		NON-CITY : STEPPED FLOOR	
STEEL, VARIABLE SPEED (TIME DELAY RELAY)		15mm (AISLE) 12mm(STEP) THICKNESS PLYWOOD WITH SMALL COIN	
		PATTERN P.V.C MAT	
		CITY : FLAT FLOOR	
		15mm THICKNESS PLYWOOD WITH SMALL COIN PATTERN P.V.C MAT	
Electrical		Audio	
BATTERY	12V DC/MF-150AH 2PIECE	STEREO W/O ECHO TYPE	AM/FM RADIO, CASSETTE STEREO,
ALTERNATOR	24V DC/120AMP		5 SPEAKERS
STARTER	24V DC/6.0KW	ANTENNA	SIDE-GENERAL TYPE
Meter & Gauge		MIC & JACK	
SPEEDOMETER & ODOMETER		Interior Equipments	
AIR PRESSURE GAUGE		DEFROSTER	HOT AIR
FUEL GAUGE		DRIVER SEPARATOR	P.V.C COATING PIPE W/SCREEN
VOLTMETER		ENTRANCE SEPARATOR	P.V.C COATING PIPE W/SCREEN
TACHOMETER (RPM METER)		ENTRANCE HANDLE	P.V.C COATING PIPE
WATER TEMPERATURE GAUGE		CEILING HANDLE	NON-CITY : P.V.C COATING PIPE (1ROW)
ENGINE OIL PRESSURE GAUGE			CITY : P.V.C COATING PIPE (3ROW) & RING
Seat		DRIVER CONSOLE BOX	
DRIVER SEAT		Accessories	
TYPE	AIR - SUSPENSION TYPE	BUMPER (FRONT & REAR)	STEEL
UPHOLSTERY	CLOTH COVERING	OUTSIDE REAR VIEW MIRROR	CONVEX MIRROR
SAFETY BELT	3 POINT WITH ALARM	TOWING HOOK	FRONT & REAR
PASSENGER SEAT		FIRE EXTINGUISHER	ABC TYPE (0.8kg)
TYPE	NON - RECLINE TYPE	SUNSHADE	NON-CITY : CURTAIN TYPE(LH)
UPHOLSTERY	VINYL LEATHER COVERING		CITY : ACRYL TYPE(LH)
Glass		BATTERY STORAGE	STEEL COMPARTMENT
WINDSHIELD	NON-CITY : 2 SECTION UPPER TINTED LAMINATED CLEAR	VENTILATOR	3 LARGE HATCHES ON ROOF
	CITY : 3 SECTION UPPER TINTED LAMINATED CLEAR	EMERGENCY HAMMER	2 EA
SIDE WINDOW	NON-CITY : HALF OPENING TYPE TEMPERED CLEAR	TOOL SET	
	CITY : FULL OPENING TYPE TEMPERED CLEAR		
REAR WINDOW	1 SECTION FIXED TYPE TEMPERED CLEAR		
DRIVE WINDOW	SLIDING TYPE TEMPERED CLEAR		

BS106 OPTION SPECIFICATION

Options

ENGINE	BODY	<input type="checkbox"/> Inside roof rack - One piece
<input type="checkbox"/> DE12TI (280ps/115kgf.m)	<input type="checkbox"/> Middle folding entrance door	<input type="checkbox"/> Destination board - Front & rear
<input type="checkbox"/> DE08TIS (240ps/90kgf.m, EURO II)	<input type="checkbox"/> Rear folding entrance door	<input type="checkbox"/> Curtain assembly at side & rear
<input type="checkbox"/> DE12TIS (290ps/115kgf.m, EURO II)	<input type="checkbox"/> Acceleration lock (middle)	HVAC
<input type="checkbox"/> DL08 (300ps/115kgf.m, EURO III)	<input type="checkbox"/> Acceleration lock (rear)	<input type="checkbox"/> Roof on cooler (24,000/26,000 kcal/h)
<input type="checkbox"/> GE12TI (290ps/115kgf.m, CNG)	<input type="checkbox"/> Emergency door <input type="checkbox"/> Driver door	<input type="checkbox"/> Auto ventilator
CHASSIS	SEAT	<input type="checkbox"/> Passenger heater
<input type="checkbox"/> RHD	<input type="checkbox"/> Conductor seat	<input type="checkbox"/> Preheater
<input type="checkbox"/> Auto T/M	<input type="checkbox"/> Cloth covering passenger seat	ELECTRICAL
<input type="checkbox"/> Speed limiter	<input type="checkbox"/> Safety belt - Reel type	<input type="checkbox"/> Analog clock <input type="checkbox"/> Digital clock
<input type="checkbox"/> Tire-10.00R-20-16PR <input type="checkbox"/> Tire-11.00-20-16PR	<input type="checkbox"/> Safety belt - Button type	<input type="checkbox"/> Carvision (back eye camera)
<input type="checkbox"/> Tire-11.00R-20-16PR <input type="checkbox"/> Tire-11R-22.5-16PR	<input type="checkbox"/> 31+1 (front/middle door)	<input type="checkbox"/> Hot & Cold cabinet
<input type="checkbox"/> Wheel cap	<input type="checkbox"/> 41+1 (front/middle door)	<input type="checkbox"/> 14" TV & VCR
<input type="checkbox"/> Front stabilizer bar <input type="checkbox"/> Auxiliary 110liter fuel tank	<input type="checkbox"/> 41+1 (front door)	<input type="checkbox"/> 17"/20" TV & VCR
<input type="checkbox"/> Automatic drain valve	<input type="checkbox"/> 45+1 (front/rear door)	<input type="checkbox"/> 'V' type TV antenna
<input type="checkbox"/> Coolant corrosion inhibitor filter	<input type="checkbox"/> 49+1 (front door)	<input type="checkbox"/> 'UFO' type TV antenna
<input type="checkbox"/> Anti freeze pump <input type="checkbox"/> Air gun set	TRIM	<input type="checkbox"/> Tachograph (electrical)
<input type="checkbox"/> Alternator-150AMP <input type="checkbox"/> Auto greaser	<input type="checkbox"/> Fixed type side window	<input type="checkbox"/> Stop button buzzer
<input type="checkbox"/> Heavy duty radiator (without fan clutch)	<input type="checkbox"/> Half opening type side window	
<input type="checkbox"/> Twin air horn <input type="checkbox"/> ABS & ASR	<input type="checkbox"/> Full opening type side window	
<input type="checkbox"/> Auto slack adjuster <input type="checkbox"/> Dual element air cleaner	<input type="checkbox"/> Colored glass	



DAEWOO BUS

▪ EXPORTER

DAEWOO BUS GLOBAL CORPORATION

202-1,Ojung-dong, Ojung-gu, Bucheon, Gyeonggi-do, Korea
Tel:82-32-680-6611~27 Fax:82-32-680-6610
<http://global.daewoobus.com>

▪ MANUFACTURER

DAEWOO BUS CORPORATION

188-9,Jeonpo-dong, Busan Jin-gu, Busan, Korea
Tel:82-51-811-4210, 520-5166~9 Fax:82-51-811-4055, 520-5147
<http://www.daewoobus.co.kr>





ROYAL CITY

BS106